

Encore[®] LT Air Filter Kit

Installation

This kit is used with both Manual Wall/Rail Mount Systems and Automatic Single/Dual Controllers.

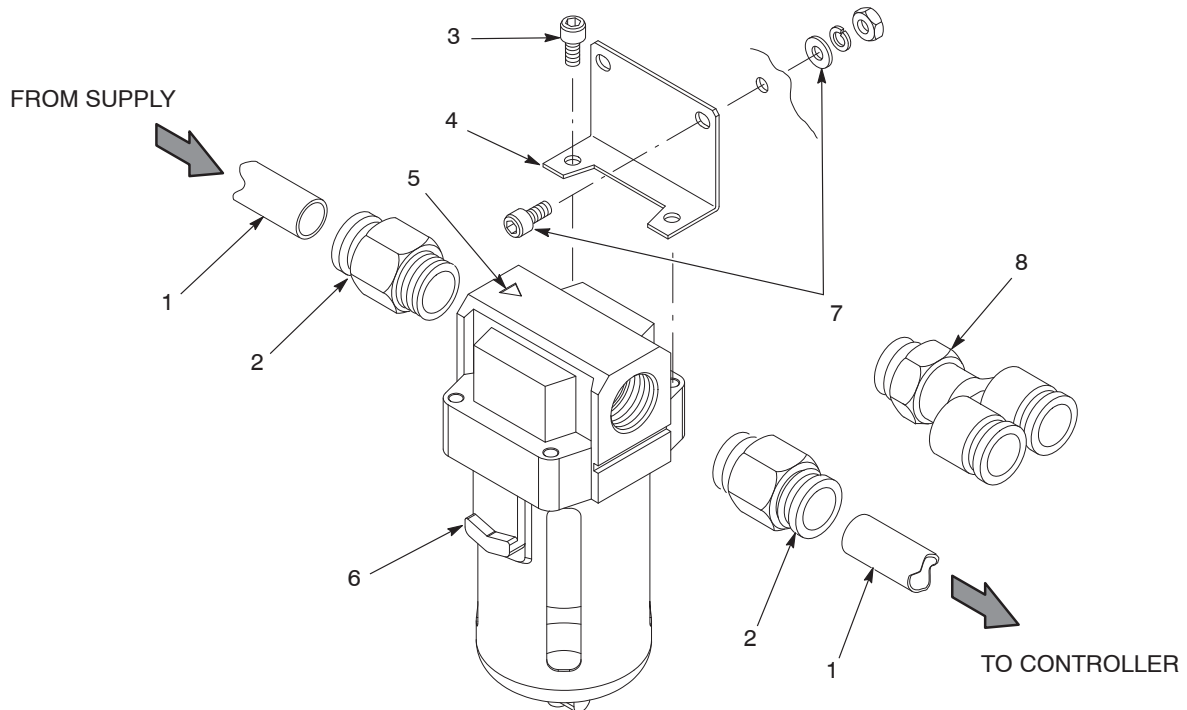

- | | | |
|-------------------------------------|-------------------|--------------------------------|
| 1. 10-mm air tubing (blue) | 4. Bracket | 7. Customer-supplied fasteners |
| 2. 10-mm tube x 1/2 male connectors | 5. Flow indicator | 8. Y-branch tube connector |
| 3. M5 screws | 6. Release latch | |

1. Use the mounting bracket (4) as a template to mark and drill mounting holes in the selected mounting surface. Make sure there is sufficient clearance to connect air tubing and change the filter element.
2. Manual or Single Automatic Systems: Install the two 10-mm tube x 1/2 male connectors (2) included in the kit in the filter input and output ports.
Dual Automatic Systems: Install a 10-mm tube x 1/2 male connector (2) in the input port. Install the Y branch connector (8) in the output port.

2 Encore® LT Air Filter Kit Installation

3. Install the mounting bracket on the filter, using the included M5 screws (3), on the side of the filter opposite the release latch (6).
4. Mount the filter with customer supplied fasteners (7).
5. Note the orientation of the flow indicator (5) on the top of the filter. Cut 10-mm blue air tubing to the required lengths to connect the air supply to the filter and the filter to the controller(s), then connect the tubing.

Parts

Part	Description	Note
1600566	KIT, filter, Encore LT	
1600608	• FILTER, mist separator, 0.3 micron, 1/2 in. NPT	
1600609	• • FILTER ELEMENT, mist separator, 0.3 micron	
971103	• CONNECTOR, male, 10 mm tube x 1/2 unithread	
1600607	• CONNECTOR, Y branch, 10 mm tube x 1/2 unithread	
-----	• BRACKET assembly, mounting, modular air filter	A
NOTE A: Bracket includes two M5 screws.		

Issued 9/2011

Original copyright date 2011. Encore, Nordson, and the Nordson logo are registered trademarks of Nordson Corporation.